

Magneti Marelli Double Ended Coil BAE801



Brand: Magneti Marelli

Product Code: BAE801

Availability: 7 Days

Weight: 0.20kg

Dimensions: 10.00cm x 10.00cm x 5.00cm

Price: \$123.75

Short Description

A compact high energy cost effective double ended ignition coil for inductive ignition systems to be used with std. ignition modules. Particularly suitable for four cylinder engines with "wasted spark" arrangement.

Description

Main Features

Simple ignition system design mainly on 4, 6 or 8 cylinder engines. Can be triggered directly from Magneti Marelli ECU's without the need for external modules.

Technical Characteristics

Nominal supply voltage	12 V
Charge current	6 A
Dwell	< 3.5 ms
Rise time	< 19 ?s
Sec. Voltage (under 1 M?)	> 25 kV
Spark duration	2.1 ms
Combustion energy	60 mJ
Connector type	Minitimer 3 ways
Weight	403 g

Technical Drawings

Dimensions in millimetres

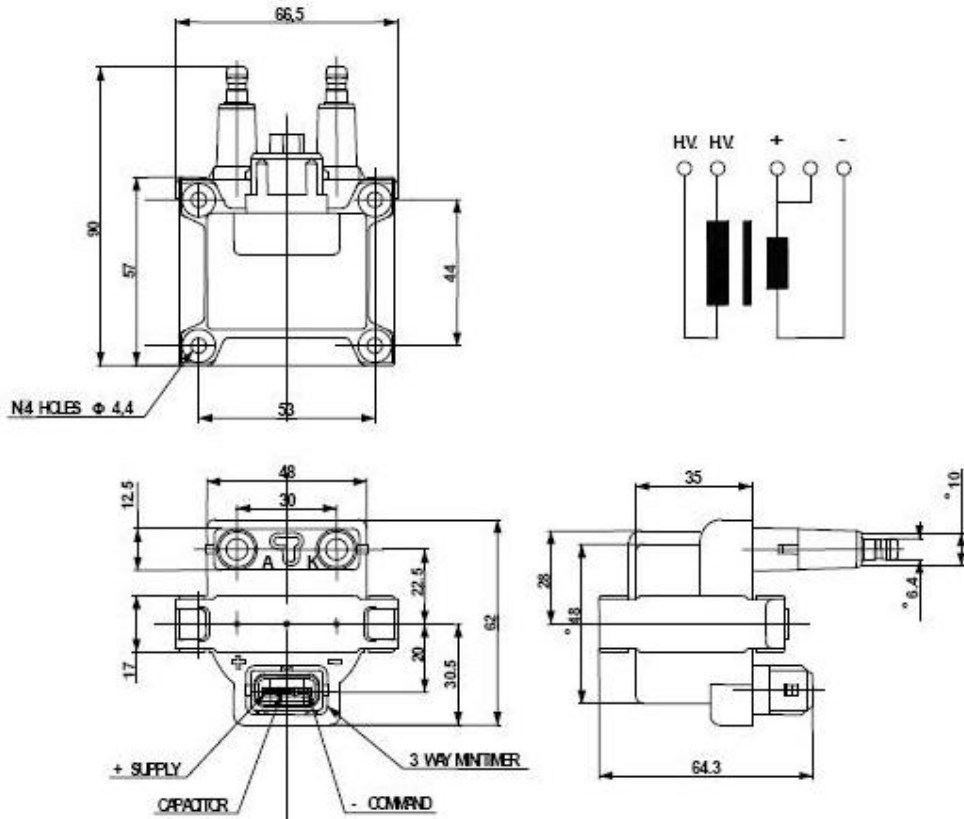

Wiring and Installation

Pin

Function

Wire

1	Power	20AWG
2	Power	20AWG
3	Ignition Command	20AWG

Connector Housing: AMP827578-1

Terminals:AMP925590-1 (20-24AWG)

These coils require an ECU which can directly drive a coil (MARELLI SRAE/SRTE/MARVEL) or an external ignitor or CDI module for operation